

# 12-RIB STYLE - FLUSH HEAD

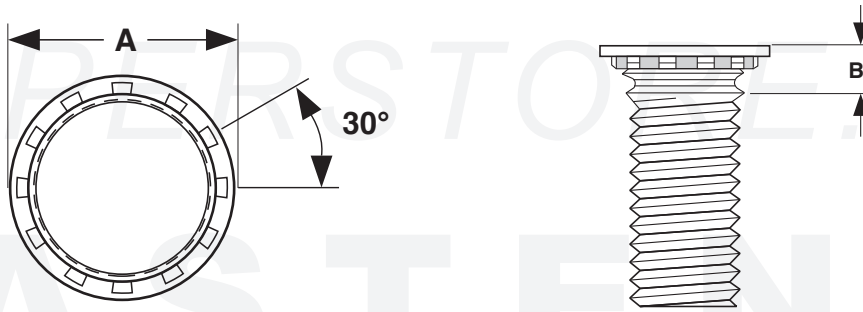

STEEL SELF-CLINCHING STUDS - 12-RIB STYLE WITH ANNULAR GROOVE									
Thread Size	A		B	Minimum Sheet Thickness	Hole in Sheet (+.003, -.000)	Distance to Center of Hole in Panel	Push-Out (lbs.)	Torque-Out (In.-lbs.)	Estimate of Installation Force in Steel
	Head Diameter		Unthreaded Length						Tons (Approx)
	Max	Min	Max						
2-56	.156	.125	.075	.040	.085	.18	250	8.5	3
4-40	.204	.172	.085	.040	.111	.22	280	11	4
5-40	.207	.177	.085	.040	.113	.22	280	11	4
6-32	.219	.187	.090	.040	.137	.25	350	30	4.5
8-32	.250	.218	.090	.040	.163	.28	400	65	5
10-24	.266	.234	.100	.040	.189	.28	500	100	6
10-32	.266	.234	.100	.040	.189	.28	500	100	6
1/4-20	.344	.312	.135	.062	.249	.31	700	120	7
1/4-28	.344	.312	.135	.062	.249	.31	*	*	*
5/16-18	.391	.361	.160	.093	.311	.38	850	200	8
3/8-16	.467	.435	.185	.125	.374	.45	1000	260	8.5
1/2-13	.640	.630	.170	*	.502	.62	1250	290	9.5
Tolerance on Length				±.015					

\*Standards are unavailable.

<b>Description</b>	A fastener with unified thread pitch and a cylindrical, low profile head with small, rectangular ribs protruding from the underside of the head. The top of the head is flat and is flush with the mating surface when installation is complete. Below the ribs and above the first thread is an annular groove which helps to hold the fastener in position.	
<b>Applications/Advantages</b>	Intended for metal panel-to-panel applications and well-suited for use in printed circuit boards. A hole is pierced into the circuit board and the unit it is attached to. The stud is inserted using a hand press or by hand, applying parallel squeezing forces. A hex nut is twisted onto the stud, securing it from the back. As the nut is tightened, the ribbed stud head grips the front panel to secure the application from the front as well, eliminating the need for welding. As the application force is applied, part of the sheet cold flows into an undercut under the head, making the fastener an integral part of the sheet.	
<b>Material</b>	<i>Steel</i>	<i>Stainless</i>
	Low carbon steel	300 series stainless
<b>Heat Treatment</b>	Clinch studs shall be case hardened, oil quenched and tempered.	
<b>Case Hardness</b>	Rockwell C 45 minimum	Not required to test for hardness
<b>Core Hardness</b>	Rockwell C 29 - 38	Not required to test for hardness
<b>For Use In...</b>	...materials with a hardness of Rockwell B80 or less.	...materials with a hardness of Rockwell B70 or less.
<b>Finish</b>	Steel clinch studs are usually furnished with a zinc plating.	Stainless clinch studs are usually supplied without additional finish.

# 12-RIB STYLE - FLUSH HEAD

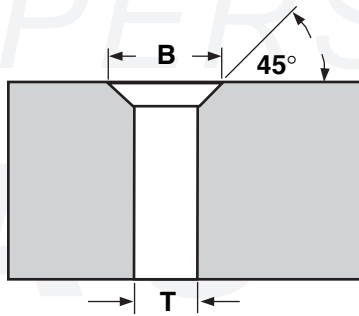

### THIN SHEET ANVIL

Intended for panels less than 0.060" in thickness, with #4 thru #10 thread sizes, inclusive. Also, for panels less than 0.093" in thickness with 1/2" thread size.

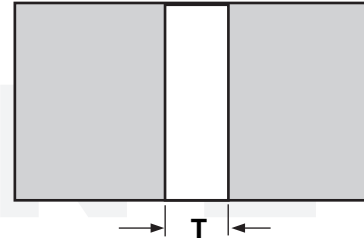

### THICK SHEET ANVIL

Intended for panels 0.060" and greater in thickness, with #4 thru #10 thread sizes, inclusive. Also, for panels 0.093" and greater in thickness with 1/4" thread size.

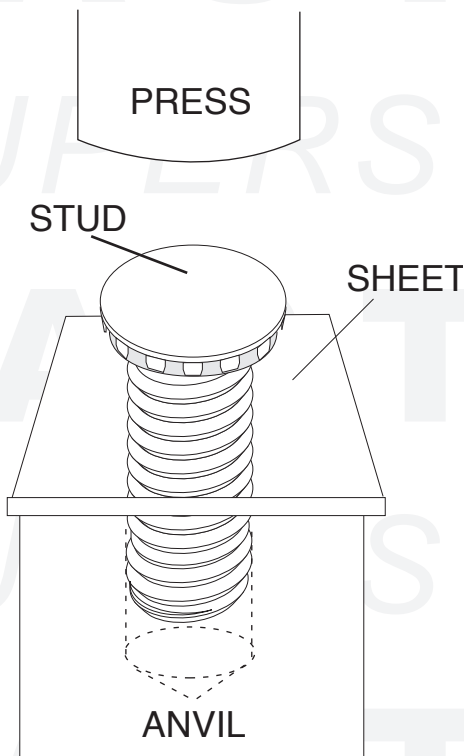

ANVIL DIMENSIONS		
Thread Size	Anvil	
	B	T
2-56	0.110	0.087
	0.114	0.090
4-40	0.136	0.113
	0.140	0.116
6-32	0.162	0.139
	0.166	0.142
8-32	0.188	0.165
	0.192	0.168
10-24 & 10-32	0.216	0.191
	0.220	0.194
1/4-20	0.295	0.250
	0.300	0.253
5/16-18	0.355	0.3125
	0.360	0.3155
3/8-16	0.465	0.3750
	0.470	0.3780
1/2-13	0.570	0.502
	0.580	0.505

**Notes on Installation:** Apply only sufficient squeezing pressure to embed head of stud flush with panel. Do not use more pressure than necessary. Amount of pressure varies with panel material and size of stud. Studs install flush in sheets .040" or thicker but will project up to .020" in thinner sheets.