

**NUTS** **DIN 934K K-Lock Nut w/ Free Spinning External Tooth LW**

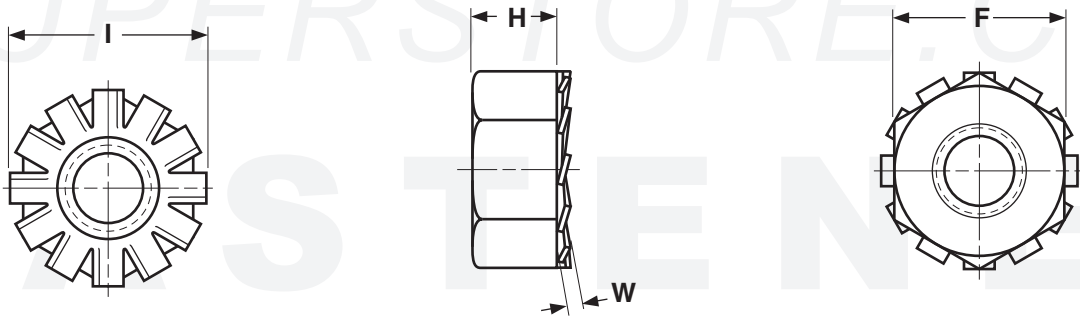

METRIC - K-LOCK NUTS							DIN 934K
Nominal Size	Thread Pitch	F		H	I		W
		Width Across Flats		Nut Thickness	Width of Washer		Washer Thickness
		Max	Min	Max	Max	Min	Ref
M3	0.5	5.5	5.32	2.40	7.2	7.0	0.45
M4	0.7	7	6.78	3.20	8.1	7.9	0.45
M5	0.8	8	7.78	4.0	9.3	9.1	0.60
M6	1.0	10	9.78	5.0	11.15	10.85	0.60
M8	1.25	13	12.73	6.50	15.1	14.7	0.80
M10	1.5	17	16.73	8.0	19.0	18.6	0.90
M12	1.75	19.0	18.7	10.0	22.0	21.6	-

<b>Description</b>	A hex nut with metric thread pitch, pre-assembled with a free spinning external tooth lock washer. The locking action is achieved when the nut is tightened against a bearing surface as the teeth of the lock washer dig into it.	
<b>Applications/ Advantages</b>	This is the most popular type of locknut because of its versatility, cost and ease of installation. Doesn't gall screw threads.	
<b>Material</b>	<b>Steel</b>	<b>Stainless</b>
	<i>Nuts</i> shall be made from a low carbon steel which conforms to the following chemical composition requirements-- <b>Carbon:</b> 0.58% maximum; <b>Manganese:</b> 0.25% minimum; <b>Phosphorous:</b> 0.060% maximum; <b>Sulfur:</b> 0.150% maximum; <b>Washers:</b> Spring steel.	<b>Nuts</b> A2 Stainless <b>Washers:</b> A2 Stainless
<b>Hardness</b>	<b>Nuts-</b> M3 - M4: Vickers HV 180 - 302 (Rockwell B87.1 - C30); M5 - M10: Vickers HV 200 - 302 (Rockwell B91.5 - C30) <b>Washers-</b> Rockwell C 41 - 47	-
<b>Plating</b>	See Appendix-A for information about the plating of steel nuts.	Stainless nuts are provided with no additional finish.