

DIN 929 Piloted Hex Multi-Projection—Weld

NUTS

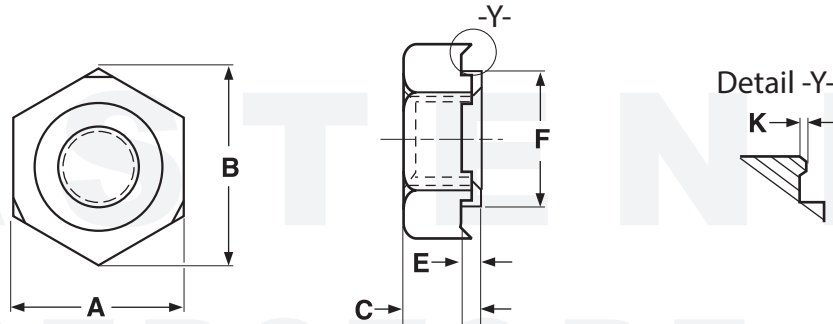

METRIC DIN 929 WELD NUTS - PILOTED HEX WITH MULTIPLE PROJECTIONS					DIN 929
Size	A	C	E	F	K
	Nut Width Across Flats	Nut Thickness	Pilot Height	Welding Pilot Diameter (Max)	Projection Height
M4-0.7	9.00	3.50	0.65	6.0	0.35
	8.78	3.20	0.55		0.25
M5-0.8	10.00	4.00	0.70	7.0	0.40
	9.78	3.70	0.60		0.30
M6-1.0	11.00	5.00	0.75	8.0	0.40
	10.73	4.70	0.60		0.30
M8-1.25	14.00	6.50	0.90	10.5	0.50
	13.73	6.14	0.75		0.35
M10-1.5	17.00	8.00	1.15	12.5	0.65
	16.73	7.64	0.95		0.50

Description	A six-sided, internally threaded fastener with three triangular weldable projections on the top surface of every other corner of the fastener. The threaded hole runs through the center and has a pilot for the entire circumference of the opening which extends above the top surface of the nut and above the projections. The remainder of the top surface of the nut is flat.	
Applications/ Advantages	This weld nut is designed to achieve two ends: (1) the pilot is self-locating so it can be used with an automated feeding mechanism; (2) when the nut is fully tightened, the pilot protects the internal threads from welding residue.	
Material	Steel	Stainless
	Class 8 Steel	A2 or A4 Stainless