

Heavy Hex,
Thin Height

Nylon Insert (Elastic) Stop Nuts

Nuts

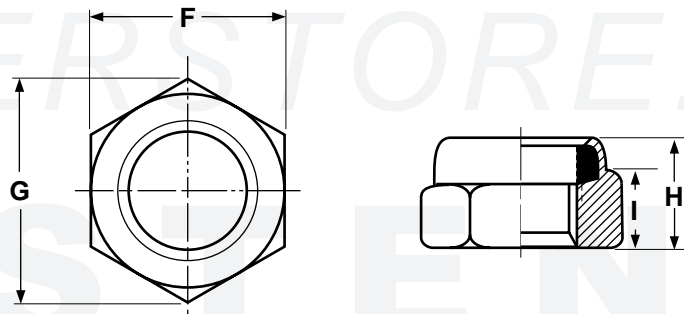

NYLON INSERT STOP NUTS, HEAVY HEX, THIN PATTERN									Esna®
Nominal Size or Basic Thread Diameter		Esna® Part Numbers	F		H		I	G	
		Steel, Zinc-plate	Width Across Flats		Thickness		Side Height	Width Across Corners	
		Coarse	Max	Min	Max	Min	Ref	Ref	
1/4	0.2500	21NTU-040	0.502	0.492	0.296	0.266	0.194	0.552	
5/16	0.3125	21NTU-058	0.564	0.553	0.328	0.298	0.212	0.622	
3/8	0.3750	21NTU-066	0.690	0.679	0.421	0.391	0.251	0.766	
7/16	0.4375	21NTU-074	0.752	0.741	0.453	0.423	0.316	0.837	
1/2	0.5000	21NTU-083	0.877	0.865	0.546	0.516	0.360	0.978	
5/8	0.6250	21NTU-101	1.064	1.052	0.624	0.594	0.428	1.191	
3/4	0.7500	41NTU-120	1.252	1.239	0.718	0.688	0.488	1.403	
7/8	0.8750	41NTU-149	1.440	1.427	0.796	0.766	0.535	1.615	
1	1.0000	41NTU-168	1.627	1.614	0.922	0.860	0.600	1.826	

Description	Identical to the NU-series heavy hex nylon insert stop nut but approximately 35% less thick from top to bottom.
Applications/Advantages	Thin pattern heavy hex nuts are used when an insufficient number of projecting threads are present to use a full heavy hex nylon insert stop nut.
Material	<u>1/4" through 5/8"</u> -- AISI 1008 - 1010 or equivalent steel; <u>3/4 through 1"</u> -- AISI C1117 or equivalent steel.
Hardness	Rockwell C 28 maximum
Plating	See Appendix-A for information about the plating of steel nylon-insert stop nuts.