

3 Projection Style

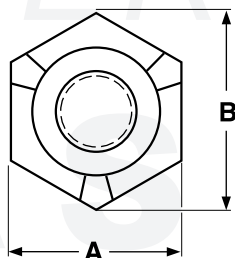

6 Projection Style

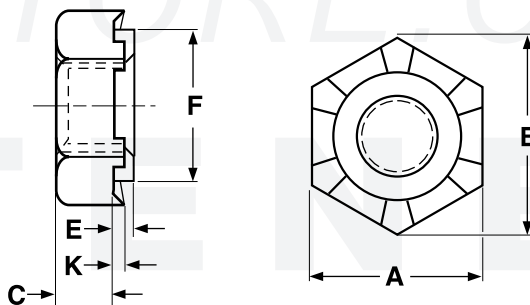

HEX PILOTED PROJECTION WELD NUTS, WITH <u>THREE PROJECTIONS</u>							Paulin®
Size	A	C	B	F	E	K	Pilot Hole
	Width	Thickness	Width Across the Corners	Pilot Diameter	Pilot Height	Projection Height	
1/4-20	.500	.198	.556	.406	.090	.043	.422
	.489	.178		.394	.080	.037	
3/8-16	.625	.260	.691	.531	.090	.043	.547
	.612	.240		.519	.080	.037	

HEX PILOTED PROJECTION WELD NUTS, WITH <u>SIX PROJECTIONS</u>							Paulin®
Size	A	C	B	F	E	K	Pilot Hole
	Width	Thickness	Width Across the Corners	Pilot Diameter	Pilot Height	Projection Height	
1/4-20	.500	.198	.556	.406	.090	.043	.422
	.489	.178		.394	.080	.037	
5/16-18	.551	.229	.624	.469	.090	.043	.484
	.562	.209		.457	.080	.037	

<b>Description</b>	A six-sided, internally threaded fastener with rounded projections on the top surface of the corners of the fastener. The six-projection style has weldable projections at all six corners; the three projection style has weldable projections atop every other corner. The threaded hole runs through the center and has a pilot for the entire circumference of the opening which extends above the top surface of the nut and above the projections. The remainder of the top surface of the nut is flat.
<b>Applications/ Advantages</b>	This weld nut is designed to achieve two ends: (1) the pilot is self-locating so it can be used with an automated feeding mechanism; (2) when the nut is fully tightened, the pilot protects the internal threads from welding residue.
<b>Material</b>	1006 - 1010 Low Carbon Steel