

HEAD DIMENSIONS

Hex & Hex Washer
Slotted & Unslotted

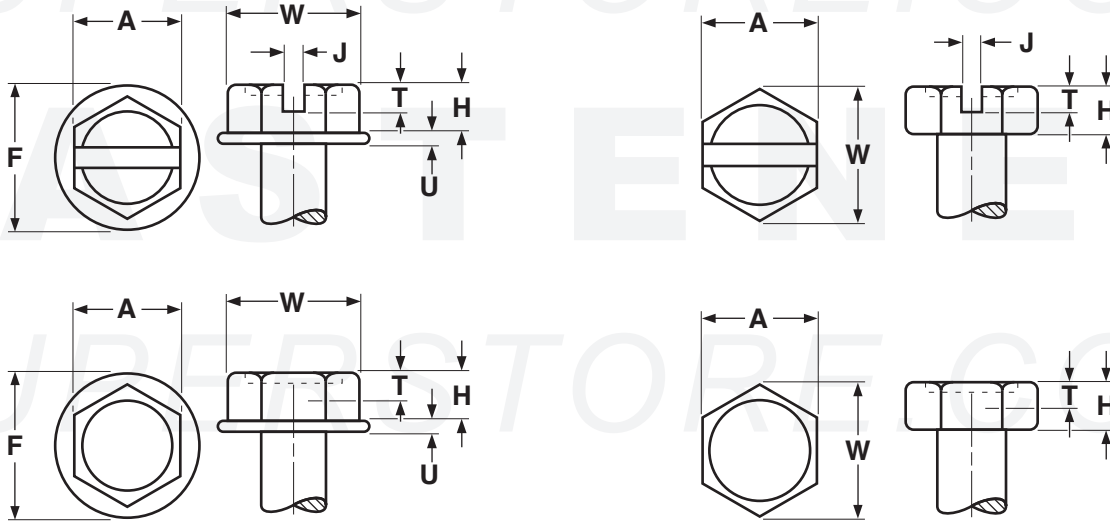

| HEX HEADS AND HEX WASHER HEADS FOR MACHINE SCREWS | | | | | | | | | | | | | ASME B18.6.3-2013 | |
|---|--------------------|------|----------------------|----------------|------|--------------------|------|---------------------|------|---------------|------|---------------|-------------------|--|
| Nominal Size | A | | W | H | | F | | U | | J | | T | | |
| | Width Across Flats | | Width Across Corners | Height of Head | | Diameter of Washer | | Thickness of Washer | | Width of Slot | | Depth of Slot | | |
| | Max | Min | Min | Max | Min | Max | Min | Max | Min | Max | Min | Max | Min | |
| 2 | .125 | .120 | .134 | .050 | .040 | .166 | .154 | .016 | .010 | - | - | - | - | |
| 4 | .188 | .181 | .202 | .060 | .049 | .243 | .225 | .019 | .011 | .039 | .031 | .042 | .025 | |
| 5 | .188 | .181 | .202 | .070 | .058 | .260 | .240 | .025 | .015 | .043 | .035 | .049 | .030 | |
| 6 | .250 | .244 | .272 | .093 | .080 | .328 | .302 | .025 | .015 | .048 | .039 | .053 | .033 | |
| 8 (standard) | .250 | .244 | .272 | .110 | .096 | .348 | .322 | .031 | .019 | .054 | .045 | .074 | .052 | |
| 8 (special) | .312 | .305 | .340 | .120 | .105 | .414 | .384 | .031 | .019 | .060 | .050 | .080 | .057 | |
| 10 | .312 | .305 | .340 | .120 | .105 | .414 | .384 | .031 | .019 | .060 | .050 | .080 | .057 | |
| 12 | .312 | .305 | .340 | .155 | .139 | .432 | .398 | .039 | .022 | .067 | .056 | .103 | .077 | |
| 1/4 (standard) | .375 | .367 | .409 | .190 | .172 | .520 | .480 | .050 | .030 | .075 | .064 | .111 | .083 | |
| 1/4 (special) | .438 | .428 | .484 | .188 | .150 | .618 | .574 | .055 | .030 | - | - | - | - | |
| 5/16 | .500 | .489 | .545 | .230 | .208 | .676 | .624 | .055 | .035 | .084 | .072 | .134 | .100 | |
| 3/8 | .562 | .551 | .614 | .295 | .270 | .780 | .720 | .063 | .037 | .094 | .081 | .168 | .131 | |
| 1/2 | .750 | .735 | .820 | .400 | .367 | 1.040 | .960 | .085 | .050 | .106 | .091 | .195 | .155 | |