

Self-Tapping Screws

Head Dimensions

Oval Undercut

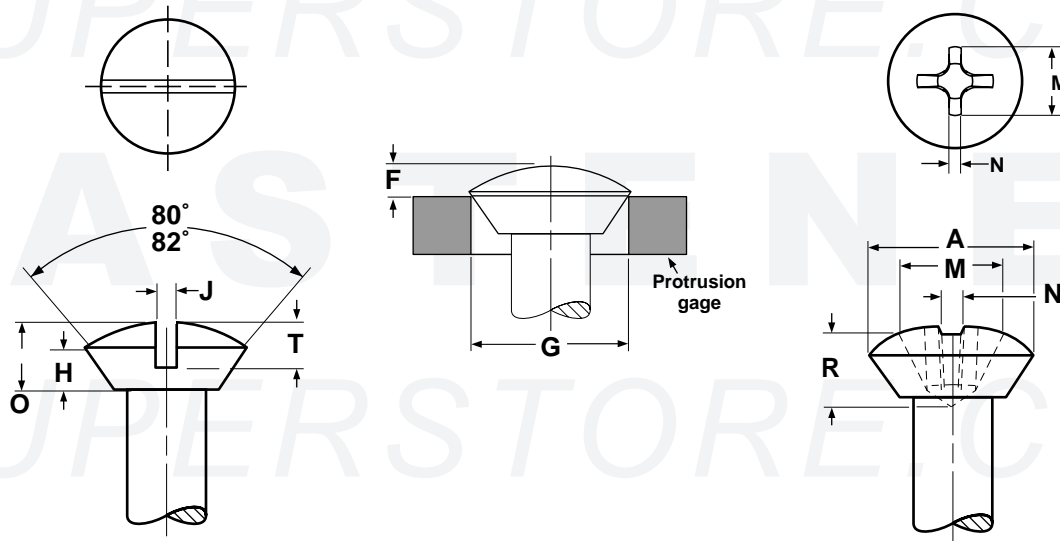

UNDERCUT OVAL HEADS FOR SELF-TAPPING SCREWS																		ANSI B18.6.4-1998	
Nominal Size	These Lengths or Shorter are Undercut		Head Dimensions						Slot Dimensions				Recess Dimensions			Protrusion Above Gaging Diameter		Gaging Diam.	Phillips Driver Size
			A		H	O		J		T		M	R	N	F		G		
			Diameter		Side Height	Total Height		Width		Depth		Diam	Depth	Width	Max	Min			
	Type AB	Other Types	Max	Min	Ref	Max	Min	Max	Min	Max	Min	Ref	Ref	Ref	Max	Min			
0	3/16	1/8	0.112	0.096	0.025	0.046	0.033	0.023	0.016	0.028	0.022	0.074	0.045	0.014	0.047	0.031	0.078	0	
1	3/16	5/32	0.137	0.120	0.031	0.056	0.042	0.026	0.019	0.034	0.027	0.077	0.048	0.015	0.053	0.035	0.101	0	
2	3/16	3/16	0.162	0.144	0.036	0.065	0.050	0.031	0.023	0.040	0.033	0.112	0.069	0.018	0.058	0.039	0.124	1	
3	7/32	7/32	0.187	0.167	0.042	0.075	0.059	0.035	0.027	0.047	0.038	0.124	0.081	0.019	0.064	0.044	0.148	1	
4	1/4	1/4	0.212	0.191	0.047	0.084	0.067	0.039	0.031	0.053	0.043	0.136	0.094	0.019	0.069	0.048	0.172	1	
5	1/4	1/4	0.237	0.215	0.053	0.094	0.076	0.043	0.035	0.059	0.048	0.158	0.085	0.028	0.075	0.053	0.196	2	
6	5/16	5/16	0.262	0.238	0.059	0.104	0.084	0.048	0.039	0.065	0.053	0.178	0.105	0.030	0.080	0.057	0.220	2	
7	3/8	3/8	0.287	0.262	0.064	0.113	0.093	0.048	0.039	0.071	0.059	0.183	0.111	0.030	0.085	0.062	0.243	2	
8	7/16	7/16	0.312	0.285	0.070	0.123	0.101	0.054	0.045	0.078	0.064	0.192	0.119	0.031	0.091	0.066	0.267	2	
10	1/2	1/2	0.362	0.333	0.081	0.142	0.118	0.060	0.050	0.090	0.074	0.209	0.137	0.033	0.102	0.075	0.313	2	
12	9/16	9/16	0.412	0.380	0.092	0.161	0.135	0.067	0.056	0.103	0.085	0.270	0.152	0.038	0.113	0.084	0.362	3	
1/4	5/8	5/8	0.477	0.442	0.107	0.186	0.158	0.075	0.064	0.119	0.098	0.290	0.173	0.040	0.129	0.095	0.424	3	
5/16	13/16	5/8	0.597	0.556	0.134	0.232	0.198	0.084	0.072	0.149	0.124	0.381	0.226	0.064	0.155	0.117	0.539	4	
3/8	-	5/8	0.717	0.670	0.161	0.278	0.239	0.094	0.081	0.179	0.149	0.400	0.245	0.066	0.182	0.139	0.653	4	
7/16	-	3/4	0.760	0.715	0.156	0.279	0.239	0.094	0.081	0.184	0.154	0.410	0.257	0.068	0.195	0.150	0.690	4	
1/2	-	3/4	0.815	0.765	0.156	0.288	0.244	0.106	0.091	0.204	0.169	0.422	0.269	0.070	0.212	0.163	0.739	4	