

**LAG SCREWS, HEX FLANGE**

Steel, Hot-Dip Galvanized

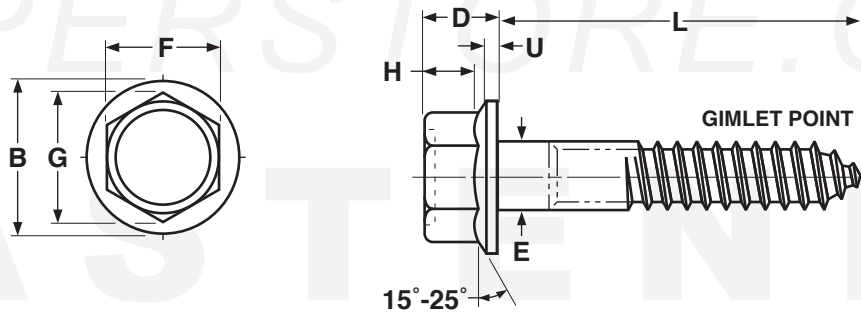

Length of a hex flange lag screw (L) is measured from the underhead bearing surface to the extreme end of the screw. Minimum thread length is 1/2 length of the screw plus 0.50 inch or 6 inches, whichever is shorter.

<b>HEX FLANGE LAG SCREWS</b>											
Nominal Size	Threads per Inch	E		F		G		B	U	D	H
		Body Diameter		Width Across Flats		Width Across Corners		Flange Diam.	Flange Thick-ness	Head Height	Wrench Height
		Max	Min	Max	Min	Max	Min	Max	Min	Max	Min
1/4	10	0.260	0.237	0.375	0.367	0.433	0.409	0.56	0.04	0.28	0.17
5/16	9	0.324	0.298	0.500	0.489	0.577	0.548	0.68	0.05	0.32	0.21
3/8	7	0.388	0.360	0.562	0.551	0.650	0.618	0.81	0.06	0.39	0.25
1/2	6	0.515	0.482	0.750	0.736	0.866	0.825	1.07	0.08	0.51	0.34
Tolerance on Length				Nominal Bolt Size		Nominal Bolt Length					
						Up to 6 inches, incl.			Over 6 inches		
				1/4 thru 1/2		± 0.12			± 0.25		

<b>Description</b>	A one-piece hex-washer head screw with a flat bearing surface, spaced threads and a gimlet point.
<b>Applications/ Advantages</b>	Useful in constructing decks and also popular in timber assembly. Preferred by some over traditional lag screws because flat washers are not required. Galvanized finish offers resistance to corrosion.
<b>Material</b>	AISI 1006 - 1022 or equivalent steel
<b>Hardness</b>	Rockwell B70 - B100
<b>Tensile Strength</b>	60,000 psi. minimum
<b>Coating</b>	Hex Flange Lag Screws are typically supplied with a hot-dipped galvanized finish. See Appendix-A for more information..