

DEEP THREAD Round Washer Head w/
Square Recess

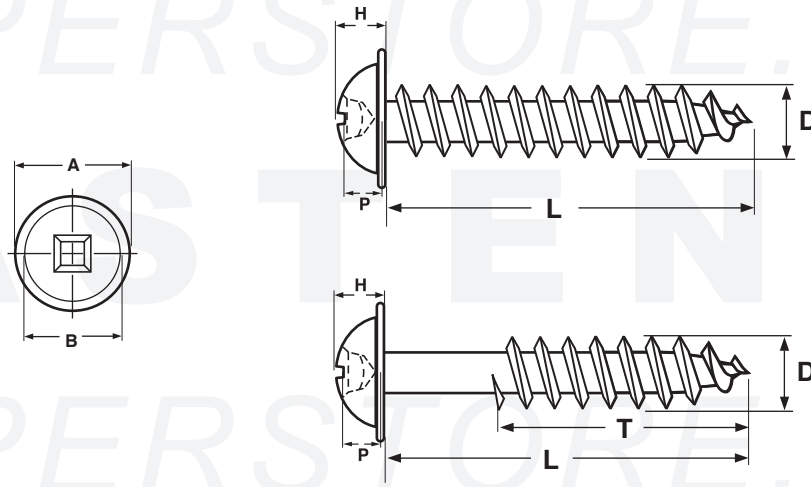

ROUND WASHER SQUARE RECESS DEEP THREAD WOOD SCREW												
Nominal Diameter	A		B	H		P		D		T		Recess Size
	Washer Diameter		Head Diameter	Total Head Height		Recess Depth		Major Diameter		Threaded Length		
	Max	Min	Ref	Max	Min	Max	Min	Max	Min	L ≤ 1"	L > 1"	
8	0.376	0.352	0.305	0.120	0.110	0.080	0.065	0.174	0.164	Full thread	2/3 thread	#2
10	0.439	0.416	0.311	0.130	0.118	0.075	0.060	0.205	0.194	Full thread	2/3 thread	#2
Tolerance on Length		Up to 5/8"										+0 / -0.03
		Over 5/8 to 1.5"										+0 / -0.05
		Over 1.5 to 2.75"										+0 / -0.06
		Over 2.75 to 5"										+0 / -0.09

Description	An externally threaded fastener with a dome-shaped head and an integrally formed washer, a square socket recess, a shank with a reduced diameter and a single lead thread.
Applications / Advantages	The deeper thread design offers greater resistance to pull-out forces. The head offers a greater bearing surface than a countersunk design. Used to attach surface-mounted door hinges or master lock hasps into dense woods or when attaching two pieces of wood through a pocket hole.
Material	C1022 case-hardened steel
Surface Hardness	Rockwell C 45 minimim
Case Depth	0.004" - 0.009"
Torque	#8 Diameter: 35 kg/cm minimum #10 Diameter: 50 kg/cm minimum
Plating	See Appendix-A for plating information