

**TYPE-17 DEEP THREAD**

**Round Washer Head w/  
Six-Lobe Recess**

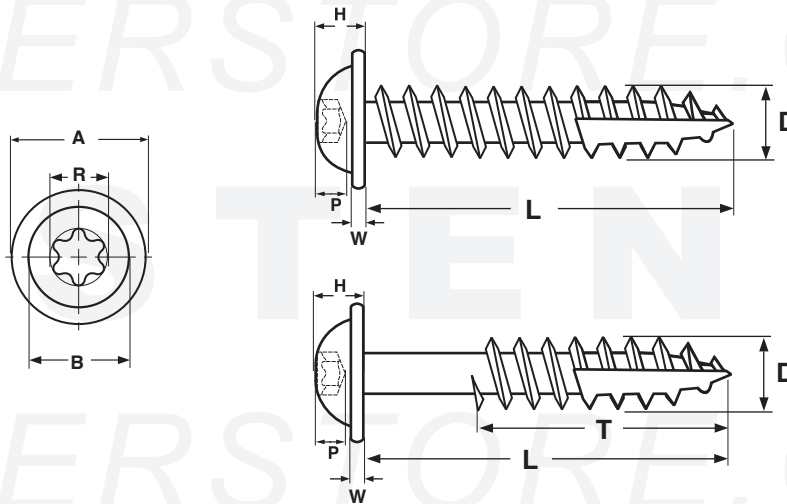

ROUND WASHER SIX-LOBE RECESS DEEP THREAD WOOD SCREW W/ TYPE-17 PT.														
Nominal Diameter & Threads per Inch	A		W	B	H		P	R	D		T		Recess Size	
	Washer Diameter		Washer Thickness	Crown Diam.	Total Head Height		Recess Penetration Depth	Recess Diam.	Major Diameter		Threaded Length			
	Max	Min	Ref	Ref	Max	Min	Min	Ref	Max	Min	L ≤ 1"	L > 1"		
8 - 11	0.380	0.358	0.040	0.259	0.113	0.101	0.050	0.155	0.168	0.161	Full Thread	Partial Thread	T20	
10 - 9	0.500	0.472	0.050	0.300	0.130	0.118	0.060	0.178	0.194	0.185	Full Thread	Partial Thread	T25	
Tolerance on Length	Up to 5/8"							± 0.03						
	Over 5/8 to 1.5"							± 0.05						
	Over 1.5 to 2.75"							± 0.06						
	Over 2.75 to 5"							± 0.09						

<b>Description</b>	An externally threaded fastener with a dome-shaped head and an integrally formed washer; a recess that can accommodate a Six-lobe screwdriver; and a single lead thread. The shank has a reduced diameter and a chip cavity cut out of the final several threads, ending at the tip.
<b>Applications / Advantages</b>	The deeper thread design offers greater resistance to pull-out forces. The round washer head is preferable in softer woods and offers a greater bearing surface than a countersunk design. The chip cavity (or auger point) enables the fastener to drive—especially in denser woods—without pre-drilling a pilot hole.
<b>Material</b>	C1018 - C1022 case-hardened steel
<b>Surface Hardness</b>	550 HV minimum
<b>Case Depth</b>	0.004" - 0.009"
<b>Torque</b>	#8: 35 Kg-cm minimum; #10: 45 kg/cm minimum
<b>Plating</b>	See Appendix-A for plating information